

# Concrete pump

Output up to 95 m<sup>3</sup>/h  
Delivery pressure up to 152 bar

# BSA 2109 H D BSA 2109 H E

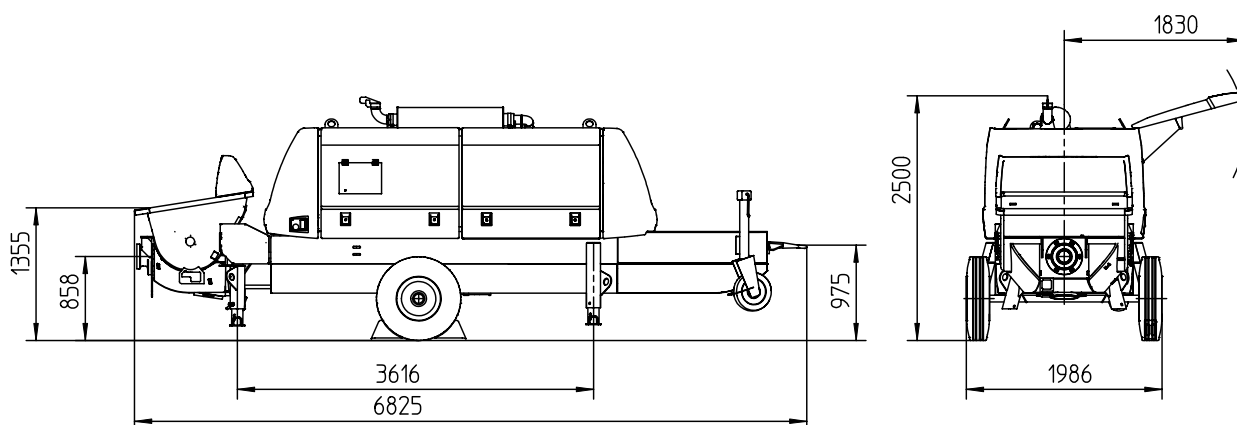

Note: Standard version BSA 2109 H D. Dimensions and weights depend on equipment.

## Performance diagram (BSA 2109 H D)

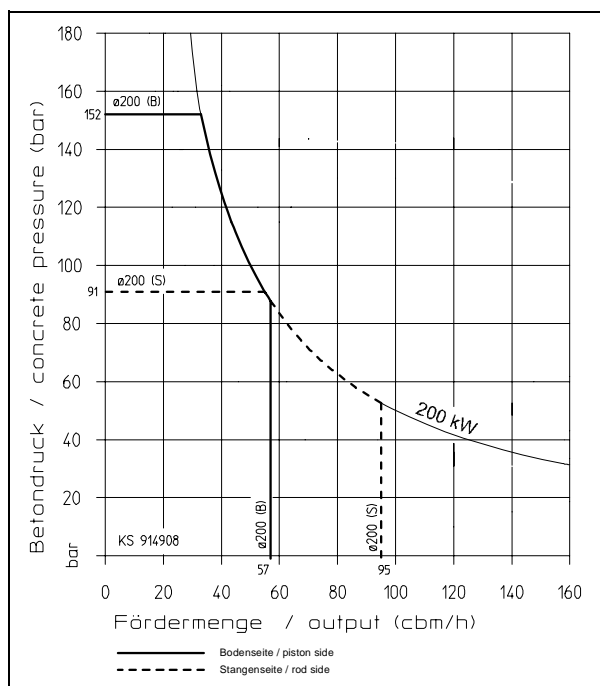

## Technical data for concrete pump

Model	BSA 2109 H -D	BSA 2109 H -E
Material number	102176.000	101503.008
Output	m <sup>3</sup> /h 95 / 57 *	85 / 51 *
Delivery pressure	bar	91 / 152 *
Delivery cylinder	∅ mm	200
Delivery cyl. stroke	mm	2100
Strokes / minute		24 / 15 *    21 / 13 *
Engine / motor power	kW	200    160 **
Hopper		RS 905 HF
Capacity	l	approx. 600
Filling height	m	approx. 1.3
Transfer tube		S 2015 D
Pressure connection	"	6
Control system		FFH-20    FFH-HD
Weight	kg	6100

\* Values for hydraulic fluid being fed to piston-side.

\*\* Electric motor with 50 Hz  
Electric motor with 60 Hz approx 20% more output / strokes

All data maximum theoretical.

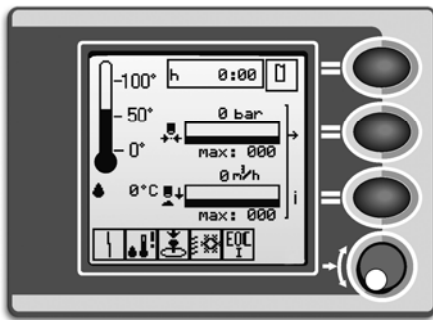

EGD - Ergonic Graphic Display

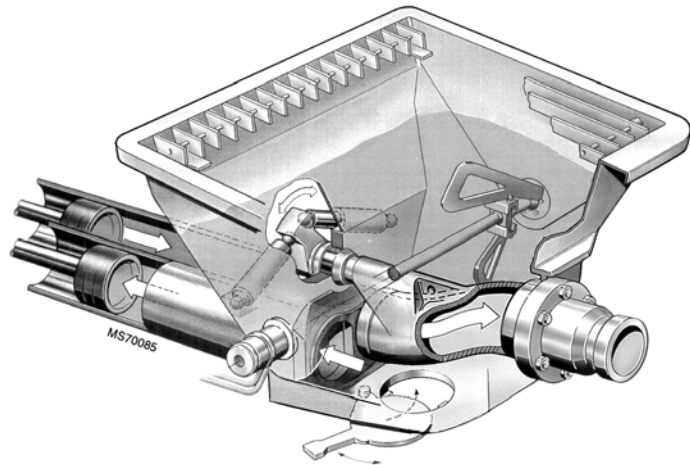

Hopper with transfer tube

### Delivery scope

- Agitator safety switch off
- Cast wear parts, highly wear resistant
- Central lubrication strip hopper
- CE-Kit
- Cleaning accessories
- Hopper with agitator
- Coupling ring (DIN)
- Drive diesel, Deutz 200 KW (BSA 2109 H D)
- Drive electric 160 KW (BSA 2109 H E)
- Gate valve connection on pump
- Flushing water pump 160 l/min 25 bar
- Grille 70 mm
- Operating manuals 2 x cert. and spare part lists
- Coloring:  
Cover MB 1227 chrome yellow / black  
Frame RAL 7035 light-grey  
Trailer RAL 7021 black-grey
- Cable remote control 10 m
- Set-up spindle, mechanically operated
- Side flaps 4x
- Splash guard
- Switching between rod side and piston-side feed
- Square outriggers 4x mech. 15°-slanging
- Storage rack
- Support wheel on tow bar
- Tool set incl. standard equipment
- Trailer F 8, can be driven on job site

### Ergonic equipment

- Output regulation, electrical
- Delivery pressure regulation, electrical (EPS)
- Operating data for pump and engine shown in Ergonic Graphic Display (EGD)
- Automatic speed reduction with „Pump Stop“
- Pump flow meter

### Optional extras

- Additional operator's manual + spare parts list 1x
- Central lubrication, electrical
- Remote control
- Rubber collar
- Vibrator, electrical
- Coupling ring (NATO)

**Please see quotation for exact delivery scope.**