

Putzmeister

Truck-mounted concrete pump BSF 46-5.16 H

.16 H LS

Output up to 160 m³/h
Delivery pressure up to 130 bar*

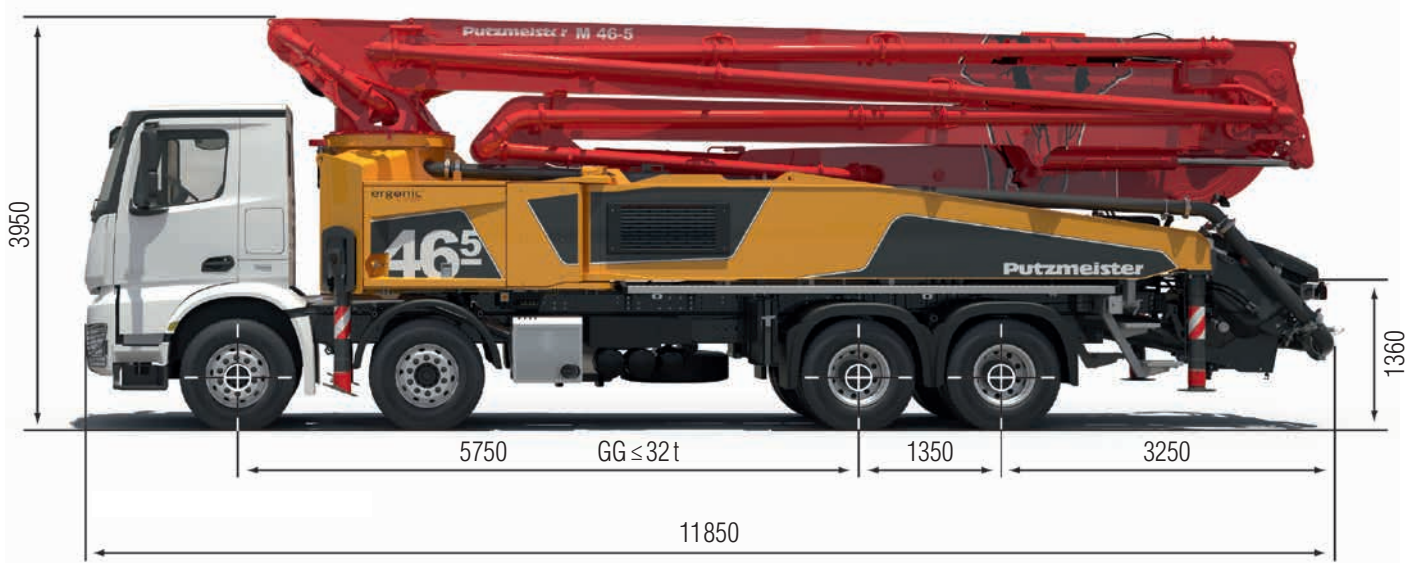
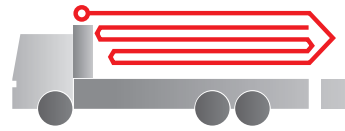

Note: Standard version. Dimensions and weights depend on truck, pump model and equipment.
Dimensions in mm, MB-Arocs 4143 as example.
For illustration only.

Technical data

Boom M 46-5		
Sections		5
Reach height	m	45.5
Horizontal reach	gross	m 40.5
	net	m 37.4
Reach depth max.	m	32.8
Unfolding height	m	11.1
End hose length	m	4
Folding system		RZ
Delivery line		DN 125

Pump		BSF	.16 H	.16 H LS
Rod side	Output	m ³ /h	160	–
	Delivery pressure	bar	85	–
	Strokes	1/min.	31	–
Piston side	Output	m ³ /h	108	160
	Delivery pressure	bar	130*	85
	Strokes	1/min.	21	26
	Delivery cylinder	Ø mm	230	250
	Stroke	mm	2100	2100

*) Delivery line boom max. 85 bar.
All data maximum theoretical.

Reach information diagram

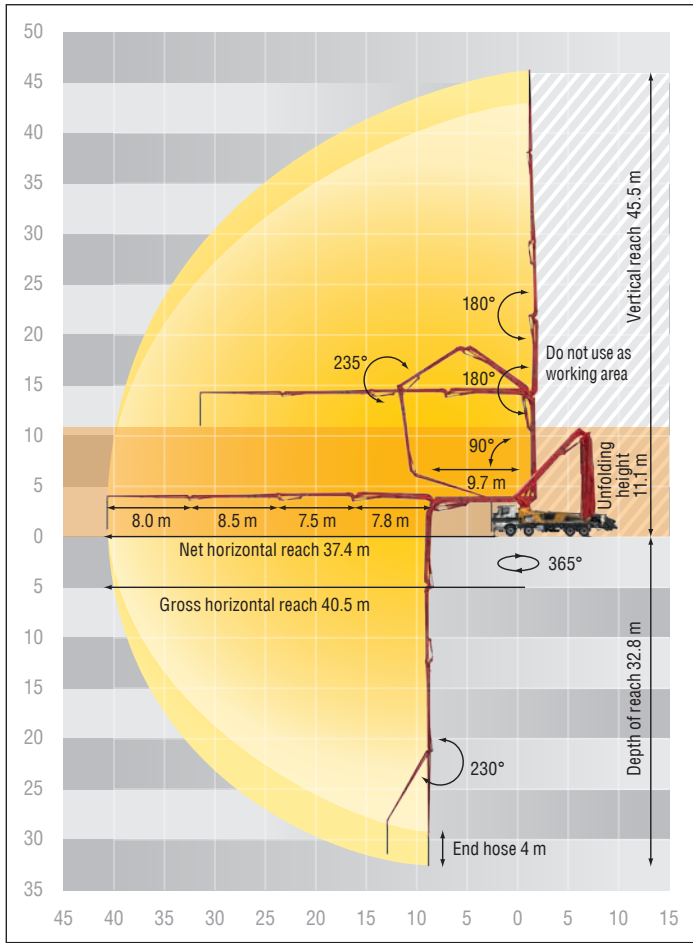

Support

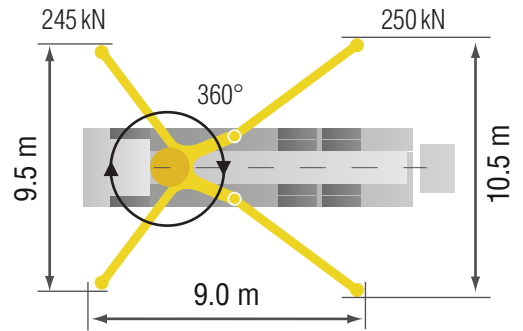

ESC

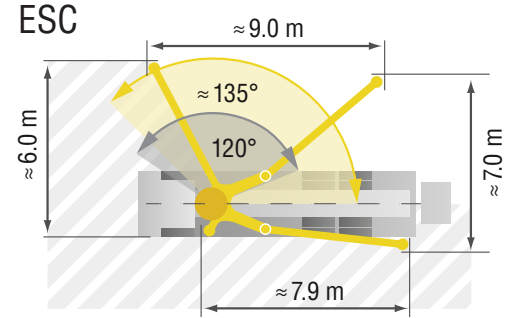

OSS

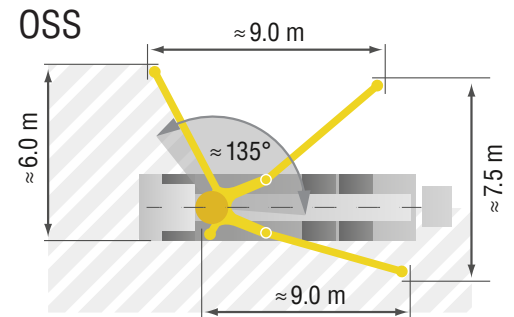

Delivery scope Standard Line

Adjustment options with machine fault management (EGD-RC)	Ergonic 2.0	Painting: 3-coloured Putzmeister standard
Agitator safety switch off, with startup protection	Ergonomic water hose reel at riser pipe	Platform non-skid
Bolted I-frame	Fail-safe S transfer tube	Radio remote control ergonic 2.0 with display, also using with cable
Bolted pipe holders	Flushing water pump 160 l/min 25 bar	Rubber collar on concrete hopper
Boom rest RFID-monitored	Fully enclosed side for simple cleaning	S-transfer tube switchover fast/slow
Box for sponge balls	Hand rail at water tank, right hand side	Spectacle wear plate DURO 22
CAN-Bus system	Hinged elbow with cleaning port	Splash guard foldable
Cardan shaft maintenance free	Hose for cleaning 10 m incl. bracket and spray nozzle	Support plates (4x)
Combined lubrication: auto lubrication of hopper, A-joint and slewing ring. Cycles adjustable.	Hydraulic fluid cooler radiator integrated in the support leg	Wash-out port lid with secured sliding pin
Concrete hopper with agitator	Hydraulic hose for replacement in hose pack	Water supply at hopper
Connection for filling water tank	LED lighting control box	Water tank 800 l
Contamination indicator hydraulic oil filter	LED lighting control sections	Wear reduced delivery line elbow with extension both sides
Delivery cylinder chrome-plated	LED lighting hopper	
Delivery note-box, plastic	Maintenance free pins rear support leg	
Diagnose interface	Maintenance-optimized support cylinder	
EOC – Ergonic Output Control	Operating manuals 2x (1x paper, 1x CD-ROM), spare part list	
EPS – Ergonic Pump System		

See quotation for exact serial delivery scope.
Comprehensive range of options available on request.